

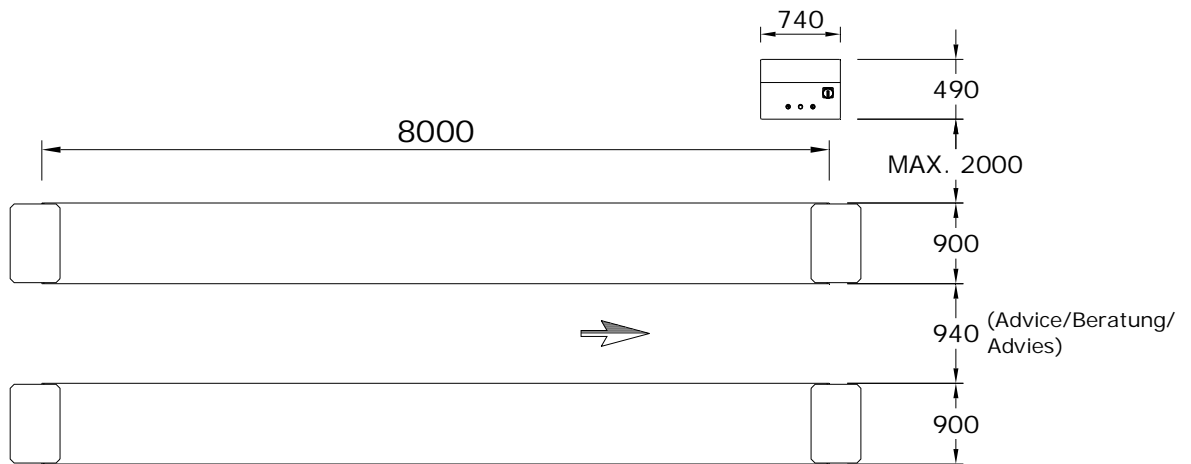

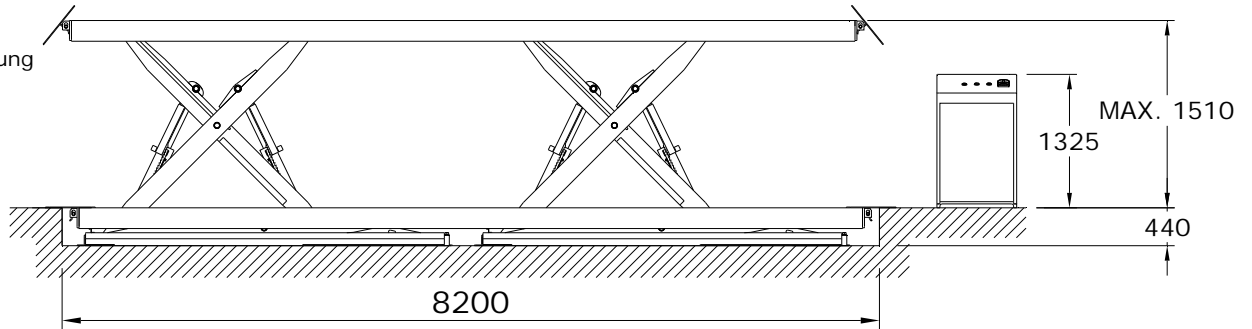

In ground version
Im Boden Ausführung
Inbouw versie

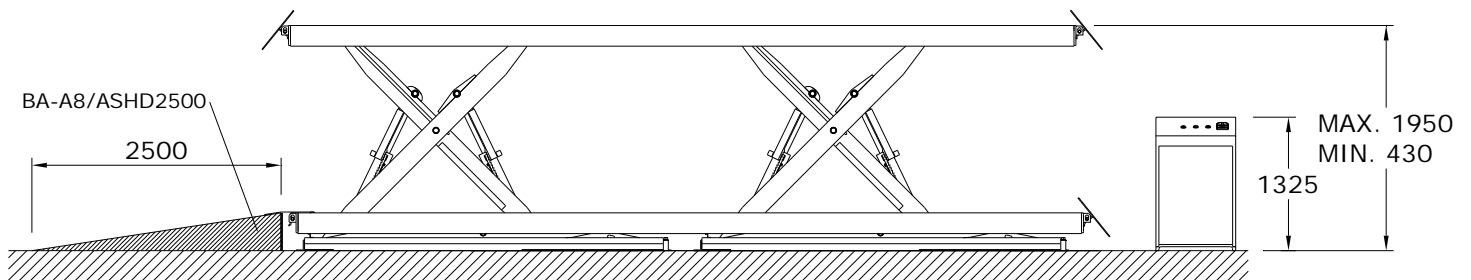

On floor version
Am Boden Ausführung
Opbouw versie





Accessories / Zubehör / Accessoires:

<p>Set (4) lighting Satz (4) Beleuchtung Set (4) verlichting</p>  <p>BA-A6/ASHD</p>	<p>Set (4) LED lighting Satz (4) LED Beleuchtung Set (4) LED verlichting</p>  <p>BA-A6LED/ASHD</p>	<p>Set (2) extra drive-on/off ramps Satz (2) extra Auffahr/Abfahrplatte Set (2) extra op-/ afrijplaten</p>  <p>BA-A8/ASHD2500 BA-A8/ASHD3000</p>
------------------------------------------------------------------------------------------------------------------------------------------------------------------------------	----------------------------------------------------------------------------------------------------------------------------------------------------------------------------------------------	-------------------------------------------------------------------------------------------------------------------------------------------------------------------------------------------------------------------------------------------------

Technical specifications / Technische Spezifikationen / Technische specificaties:

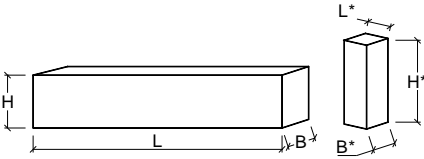
			ASHD20006
Capacity	Tragfähigkeit	Hefvermogen	20.000 kg
Lifting time	Hebezeit	Heftijd	50 s
Descent time	Absenkzeit	Daaltijd	50 s
Noise level	Lärmpegel	Geluidsniveau	70 dB (A) / 1 m
Working temp.	Arbeitstemp.	Werktemp.	0 °C / +45 °C
Motor power	Motorleistung	Motorvermogen	11 kW
Electr. Supply	Anschlußwert	Aansl. waarde	400 V / 50 Hz / 3 Ph
Pneumatic feed	Betriebsdruck	Perslucht	6-8 bar
Color	Farbe	Kleur	RAL 5015
Working envir.	Arbeitsumgeb.	Werkomgeving	Indoor/Drinnen/Binnen

<p>Packing/Verpackung/Verpakking:</p>  <p>L x B x H = 8100 x 930 x 1000 L* x B* x H* = 790 x 540 x 1410</p>	<p>Container transport:</p>  <p>40 ft. = 4 pieces/Stück/stuks</p>
-----------------------------------------------------------------------------------------------------------------------------------------------------------------------------------------------------------	---------------------------------------------------------------------------------------------------------------------------------------------------------------